



eleofire

BEYOND EXPECTATION

PELLET | ELECTRIC | WOOD | BIO ETHANOL





The warmest of welcomes

Welcome the warmth of Elcofire into your home with fires and stoves that embody elegance and epitomise efficiency.

Born out of our passion for precision engineering, our expert team has combined their collective industry knowledge, technical expertise, and customer experience to deliver products unparalleled in their design.

Our commitment to quality and sustainability means we use only the best available components and state-of-the-art manufacturing techniques to create beautiful products that will last a lifetime and beyond, providing your home with years of comfort and warmth.

BEYOND
EXPECTATION

OUR SERVICE PILLARS

We have three key principles that we stand by in the design and supply of our products and services. These service pillars help us to deliver the quality experience our customers both deserve and have come to expect.

Style

Whether a cabin or a cottage, a house or a high-rise apartment, we believe each of our products should fit effortlessly into our modern ways of living, offering a contemporary elegance and stylish aesthetic that brings a unique warmth to every home.

Sustainability

Creating the best fires for our customers also means designing the best products for the world we live in. That means pushing the boundaries not only of energy efficiency, but of longevity, sourcing components and using modern manufacturing techniques to come up with products that will last lifetimes.

Service

Warmth is not simply what our products deliver. It is a key component of the service we provide to our customers, with installation guides, service aftercare, and warranties that enable our team to provide the highest, most human level of care.

OUR SUSTAINABILITY COMMITMENT

The EU Ecodesign Directive obliges manufacturers to design energy-using products that consume less energy and improve air quality throughout their life cycle. All Elcofire fires and stoves conform to this legislation and carry Ecodesign Directive energy labelling.



High Efficiency

All Elcofire products have been designed to operate with high thermal efficiency, minimising the loss of heat energy during use. Every model in this brochure is subject to EU energy labelling standards and almost all are rated as either A or A+ energy class appliances.

Defra Exempt

Most town and city homes are located in Smoke Control Areas. To burn logs in these locations, the stove installed must be granted exemption from these restrictions by the government through DEFRA (Department for Environment Food and Rural Affairs in the UK). Independently tested to demonstrate particularly clean burning combustion, Elcofire stoves have DEFRA exemption.

Eco Design

All Elcofire stoves meet the stringent air quality standards of Ecodesign, featuring Cleanburn technology for high-efficiency heating in Smoke Control Areas. They also meet, and in many cases exceed, Ecodesign emission and efficiency standards. Our low-emission stoves reduce particulates by up to 84% compared with old appliances.

OUR PROMISE

SOLID FUEL WARRANTY

Elcofire Stoves are a quality product with a 5-year warranty for your peace of mind, which covers all stove body castings. This does not include consumable items as such as glass, door seals, grates, firebricks, vermiculite panels, baffles and log guards.

PELLET FIRE WARRANTY

Elcofire Pellet Stoves are a quality product with a 2-year warranty for your peace of mind, which covers all stove body castings. This does not include consumable items as such as glass, door seals, grates, firebricks, vermiculite panels, baffles and log guards, electrical components, all electrical components are guaranteed for 1 year.

ELECTRIC FIRE WARRANTY

Elcofire Electric Fire are a quality product with a 2-year warranty for your peace of mind, which covers all components excluding the Glass.

BIO ETHANOL WARRANTY

Elcofire Bio Ethanol Fire are a quality product with a 1-year warranty for your peace of mind, which covers all components excluding the Glass.

PRODUCT SPECIFICATIONS

Elcofire products represent the cutting edge in low-emission stoves, with an assortment of features across our range that deliver comfort in the home and environmental sustainability to the world.



Remote Control



Wi-Fi Enabled



Elcofire Clean Glass Technology



External Air



Eco Design Ready



Multi Fuel



Defra Exempt



Sustainable



electric

The Elcofire Motion® range features ultra-realistic, illuminated pulsating logs and fuel bed, offering a clean built-in design with lifelike flames rivaling real fires. Similarly, the Sol™ Range from Elcofire provides a multibox fire with a clean design and tall flames, along with illuminated logs and fuel bed for a hyper-realistic experience. It's adaptable as a 1 Sided or 2 or 3 Sided Panoramic setup.

NEW

EFMS1100

Motion Slim 1100

A+

KEY FEATURES

- Motion™ Flame & Log Technology with Ultra-Realistic Translucent Log Set
- 10 Flame Colours with Down & Ember Bed Lighting
- Black Acrylic Crystal Ember Bed
- Low Energy LED Technology with Hidden Touch Controls
- Remote Control with WiFi Enabled & Optional Crackling Sound
- Variable Heat with Timer & Flame Control
- 220 Volt Plug & DIY Installation
- 4-Sided Trim Included
- Wall Hanging Kit included
- Ultra-Slim only 130mm Depth

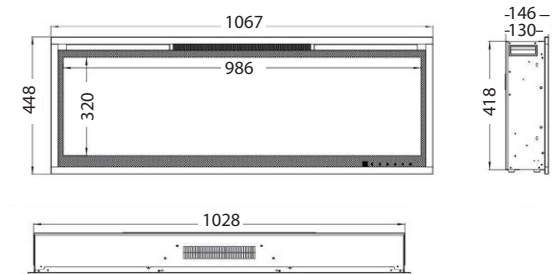

elcofire

NEW

EFMS1300

Motion Slim 1300

A+

KEY FEATURES

- Motion™ Flame & Log Technology with Ultra-Realistic Translucent Log Set
- 10 Flame Colours with Down & Ember Bed Lighting
- Black Acrylic Crystal Ember Bed
- Low Energy LED Technology with Hidden Touch Controls
- Remote Control with WiFi Enabled & Optional Crackling Sound
- Variable Heat with Timer & Flame Control
- 220 Volt Plug & DIY Installation
- 4-Sided Trim Included
- Wall Hanging Kit included
- Ultra-Slim only 130mm Depth

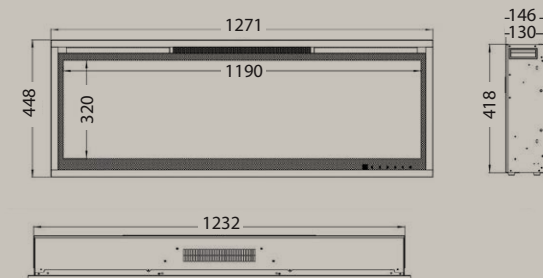



NEW

EFMS1500

Motion Slim 1500

A+

KEY FEATURES

- Motion™ Flame & Log Technology with Ultra-Realistic Translucent Log Set
- 10 Flame Colours with Down & Ember Bed Lighting
- Black Acrylic Crystal Ember Bed
- Low Energy LED Technology with Hidden Touch Controls
- Remote Control with WiFi Enabled & Optional Crackling Sound
- Variable Heat with Timer & Flame Control
- 220 Volt Plug & DIY Installation
- 4-Sided Trim Included
- Wall Hanging Kit included
- Ultra-Slim only 130mm Depth

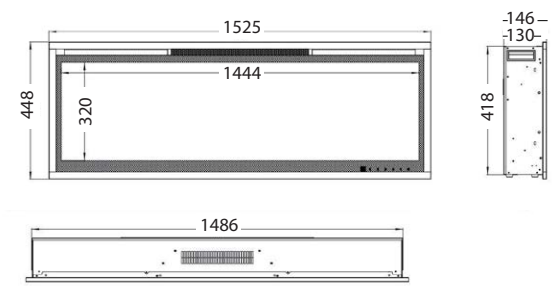

elcofire



EFM700

Motion[®] - 700

A+

KEY FEATURES

- Motion™ Flame and Log Technology
- Ultra-Realistic Illuminated Glowing/Pulsating Log Set
- 10 Unique Flame Colours with Down Lighting and Ember Bed Lighting
- Black Acrylic Crystal Ember Bed
- Low Energy LED Flame Technology
- Hidden Manual Touch Screen Button Controls
- Sleek Remote
- Can be Installed Beneath a TV
- Variable Heat with Thermostat with built in timer
- Variable Flame Controls
- 220 Volt Plug
- Do it Yourself Installation Instructions
- 4-Sided Finish Trim Kit Included
- Optional frameless kit is available, allowing you to remove the standard 4-sided frame included with the fireplace





EFM1100

Motion[®] - 1100

A+

KEY FEATURES

- Motion™ Flame and Log Technology
- Ultra-Realistic Illuminated Glowing/Pulsating Log Set
- 10 Unique Flame Colours with Down Lighting and Ember Bed Lighting
- Black Acrylic Crystal Ember Bed
- Low Energy LED Flame Technology
- Hidden Manual Touch Screen Button Controls
- Sleek Remote
- Can be Installed Beneath a TV
- Variable Heat with Thermostat with built in timer
- Variable Flame Controls
- 220 Volt Plug
- Do it Yourself Installation Instructions
- 4-Sided Finish Trim Kit Included
- Optional frameless kit is available, allowing you to remove the standard 4-sided frame included with the fireplace

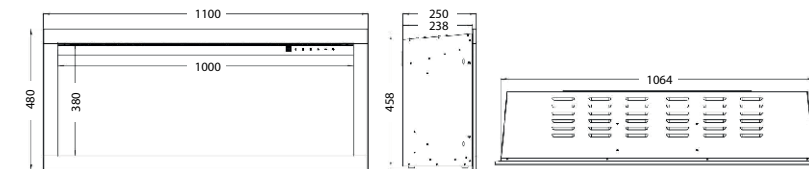

elcofire



EFM1500

Motion[®] - 1500

A+

KEY FEATURES

- Motion™ Flame and Log Technology
- Ultra-Realistic Illuminated Glowing/Pulsating Log Set
- 10 Unique Flame Colours with Down Lighting and Ember Bed Lighting
- Black Acrylic Crystal Ember Bed
- Low Energy LED Flame Technology
- Hidden Manual Touch Screen Button Controls
- Sleek Remote
- Can be Installed Beneath a TV
- Variable Heat with Thermostat with built in timer
- Variable Flame Controls
- 220 Volt Plug
- Do it Yourself Installation Instructions
- 4-Sided Finish Trim Kit Included
- Optional frameless kit is available, allowing you to remove the standard 4-sided frame included with the fireplace



NEW

EFS1000

Sol 1000

A+

KEY FEATURES

- Motion™ Flame and Log Technology
- Ultra-Realistic Illuminated Glowing/Pulsating Log Set
- 10 Unique Flame Colours with Down Lighting and Ember Bed Lighting
- Black Shattered Glass Crystal Ember Bed, Shattered base with Black & Cream dressing.
- Low Energy LED Flame Technology
- Hidden Manual Touch Button Controls
- Fully Functional Remote Control
- WIFI enabled as Standard
- On/Off Fire Crackling noise (pre-set to off)
- Can be Installed Beneath a TV
- Variable Heat with Thermostat with built in timer
- Variable Flame Controls
- 220 Volt Plug
- Do it Yourself Installation Instructions
- 4 different Installation Configuration; 3 Sided, 2 Sided or 1 Sided

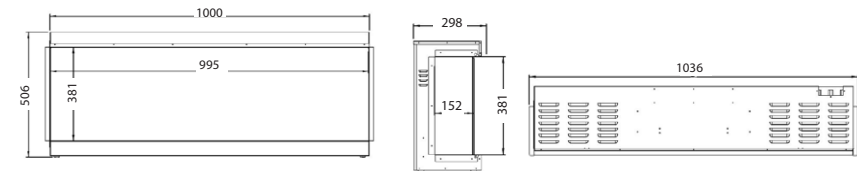

elcofire



The configuration of this sample is 1 sided

EFS1300

Sol[®] - 1300

A+

KEY FEATURES

- Motion™ Flame and Log Technology
- Ultra-Realistic Illuminated Glowing/Pulsating Log Set
- 10 Unique Flame Colours with Down Lighting and Ember Bed Lighting
- Black Shattered Glass Crystal Ember Bed, Shattered base with Black & Cream dressing.
- Low Energy LED Flame Technology
- Hidden Manual Button Controls
- Fully Functional Remote Control
- Wifi enabled as Standard
- On/Off Fire Crackling noise (pre-set to off)
- Can be Installed Beneath a TV
- Variable Heat with Thermostat with built in timer
- Variable Flame Controls
- 220 Volt Plug
- Do it Yourself Installation Instructions
- Optional 4 – Sided Edge Trim Frame for Single Sided Installations
- 4 different Installation Configuration 3 Sided, 2 Sided or 1 Sided

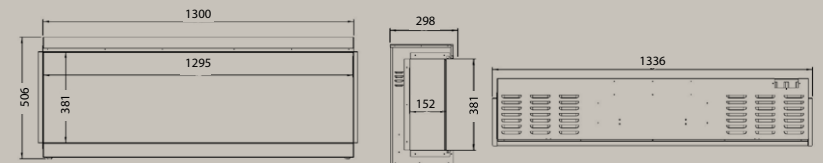



The configuration on this fire is a 3-sided View

EFS1600

Sol[®] - 1600

A+

KEY FEATURES

- Motion™ Flame and Log Technology
- Ultra-Realistic Illuminated Glowing/Pulsating Log Set
- 10 Unique Flame Colours with Down Lighting and Ember Bed Lighting
- Black Shattered Glass Crystal Ember Bed, Shattered base with Black & Cream dressing.
- Low Energy LED Flame Technology
- Hidden Manual Button Controls
- Fully Functional Remote Control
- Wifi enabled as Standard
- On/Off Fire Crackling noise (pre-set to off)
- Can be Installed Beneath a TV
- Variable Heat with Thermostat with built in timer
- Variable Flame Controls
- 220 Volt Plug
- Do it Yourself Installation Instructions
- Optional 4 – Sided Edge Trim Frame for Single Sided Installations
- 4 different Installation Configuration 3 Sided, 2 Sided or 1 Sided



elcofire





EFR400

Raven 400

A+

KEY FEATURES

- Motion™ Flame and Log Technology
- Ultra-Realistic Illuminated Glowing/Pulsating Log Set
- 10 Unique Flame Colours with Down Lighting and Ember Bed Lighting
- Black Shattered Glass Crystal Ember Bed, Shattered base with Black & Cream dressing.
- Low Energy LED Flame Technology
- Hidden Manual Touch Screen Button Controls
- Fully Functional Remote Control
- WIFI enabled as Standard
- Can be Installed Beneath a TV
- Variable Heat with Thermostat with built in timer
- Variable Flame Controls
- 220 Volt Plug
- Do it Yourself Installation Instructions
- 3 & 4 Sided included in the box.
- Also available in a Non Heat Version.

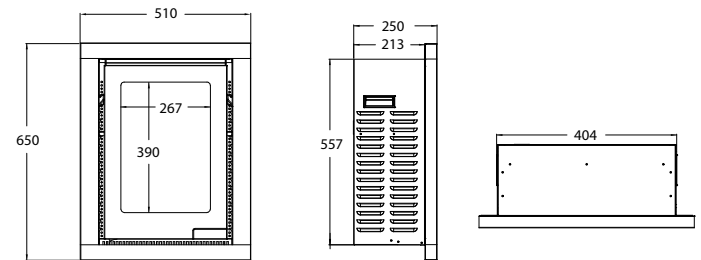

elcofire

The Raven and Terra Electric Range from Elcofire combines cutting-edge design with lifelike flame technology. Available in both cassette and free-standing stove styles, it showcases the tallest, most realistic flames on the market. The effect is enhanced by illuminated, pulsating logs and a glowing fuel bed, creating a hyper-realistic fire experience that truly rivals a real flame—bringing warmth, atmosphere, and style to any room.



EFR550

Raven 550

A+

KEY FEATURES

- Motion™ Flame and Log Technology
- Ultra-Realistic Illuminated Glowing/Pulsating Log Set
- 10 Unique Flame Colours with Down Lighting and
- Ember Bed Lighting
- Black Shattered Glass Crystal Ember Bed, Shattered base with Black & Cream dressing.
- Low Energy LED Flame Technology
- Hidden Manual Touch Screen Button Controls
- Fully Functional Remote Control
- WIFI enabled as Standard
- Can be Installed Beneath a TV
- Variable Heat with Thermostat with built in timer
- Variable Flame Controls
- 220 Volt Plug
- Do it Yourself Installation Instructions
- 3 & 4 Sided included in the box.
- Also available in a Non Heat Version

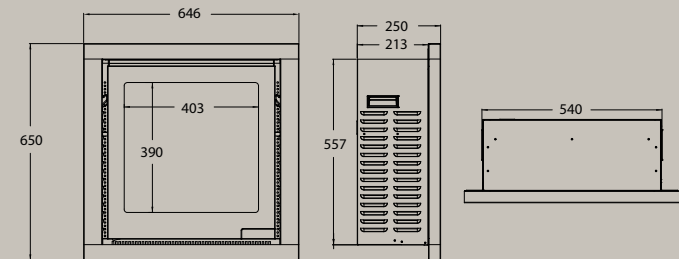



EFT550

Terra Electric Freestanding

A+

KEY FEATURES

- Motion™ Flame and Log Technology
- Ultra-Realistic Illuminated Glowing/Pulsating Log Set
- 10 Unique Flame Colours with Down Lighting and Ember Bed Lighting
- Black Shattered Glass Crystal Ember Bed, Shattered base with Black & Cream dressing.
- Low Energy LED Flame Technology
- Hidden Manual Touch Screen Button Controls
- Fully Functional Remote Control
- WIFI enabled as Standard
- Can be Installed Beneath a TV
- Variable Heat with Thermostat with built in timer
- Variable Flame Controls
- 220 Volt Plug
- Do it Yourself Installation Instructions
- Also available in a Non Heat Version.

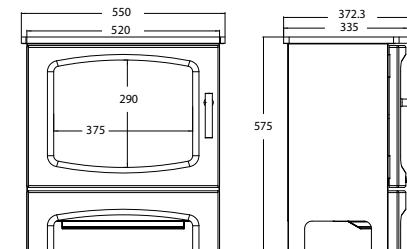

elcofire



solid fuel

The Eco Stove Range from Elcofire incorporates our unique efficient fuel burning technology, which conforms to EU Ecodesign standards and allows wood to be burnt cleanly and safely in Smoke Control Areas.



EFRCW5

Raven 5kw

A+

Our Elcofire Raven Inset Stoves feature advanced fire control technology for superior efficiency and flame management. Designed to create a stunning focal point, they offer a contemporary cast iron finish with 3 or 4-sided frames and fit comfortably into standard 16" or 22" fireplaces, making them ideal for most room sizes.

KEY FEATURES

- Fuel: Wood or Smokeless Fuel
- Heat Output: Wood/Multifuel -5kw
- Efficiency: 83.7%
- Flue Size: 125mm
- Extra-large glass door
- Sleek contemporary cast iron design
- Outstanding efficiency
- Elcofire Clean Glass Technology
- Comes Standard with 3 or 4 Sided Frame.
- Neat Hidden Flush Door Handle
- Ribbed Effect Vermiculite Internal Bricks
- External air (optional)
- Ecodesign Ready
- Easy to light and install

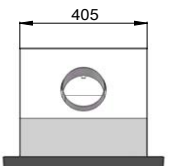
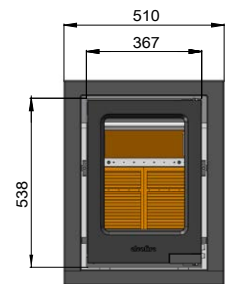
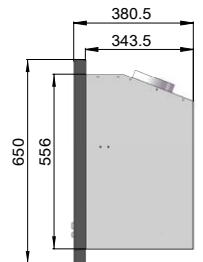

elcofire



EFRCW8

Raven 8kw

A+

KEY FEATURES

- Fuel: Wood or Smokeless Fuel
- Heat Output: Wood/Multifuel -8kw
- Efficiency: 81.7%
- Flue Size: 150mm
- Extra-large glass door
- Sleek contemporary cast iron design
- Ribbed Effect Vermiculite Internal Bricks
- Outstanding efficiency
- Elcofire Clean Glass Technology
- Comes Standard with 3 or 4 Sided Frame.
- Neat Hidden Flush Door Handle
- External air (optional)
- Ecodesign Ready
- Easy to light and install

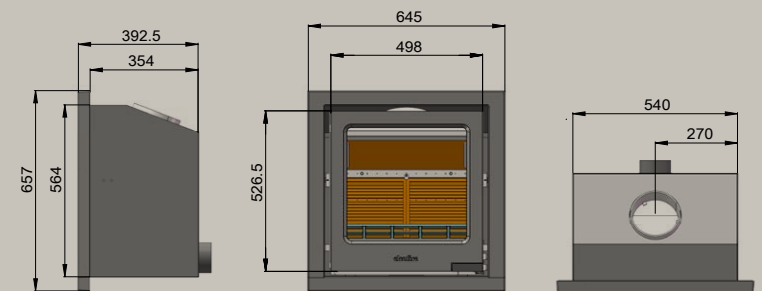



Ellen

A+

The Ellen is a sleek, freestanding wood-burning stove that combines powerful heating performance with top-tier ecological standards. Engineered with advanced technology, Ellen ensures optimal energy use — delivering efficient, economical warmth while minimizing environmental impact. Its contemporary design enhances any interior with timeless elegance, making it as much a design statement as a reliable heat source. Perfect for those who value efficiency, style, and sustainability, Ellen is where modern living meets mindful comfort.

KEY FEATURES

- Fuel: Wood or Smokeless Fuel
- Heat Output: 3 – 8kw
- Efficiency: 80.9%
- Flue Size: 146mm
- Extra-large Self Closing Glass door
- Sleek contemporary design
- Outstanding efficiency
- Elcofire Clean Glass Technology
- Cool touch Timber handle
- External air
- Ecodesign Ready
- Easy to light and install

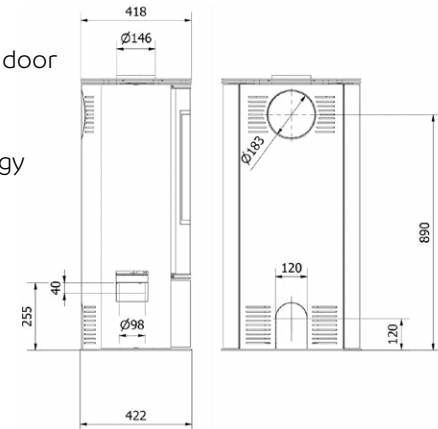
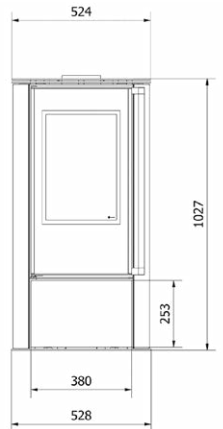

elcofire



EFLCW

Luna inset – cast iron

A+

KEY FEATURES

- Fuel: Wood or Smokeless Fuel
- Heat Output: Wood-5kw/Smokeless 6kw
- Efficiency: 83.0%
- Flue Size: 125mm
- Extra-large glass door
- Sleek contemporary design
- Outstanding efficiency
- Elcofire Clean Glass Technology
- Available with 3 or 4 sided frames
- Cool touch handle
- External air
- Ecodesign Ready
- Easy to light and install

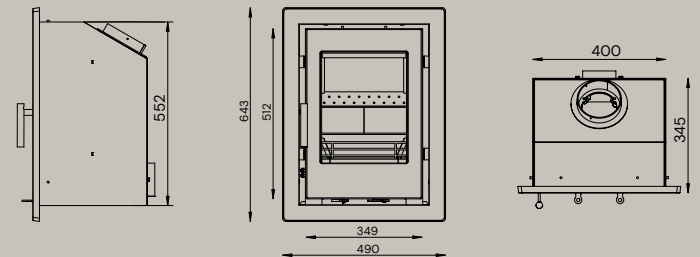



EFTW

Terra Freestanding

A+

KEY FEATURES

- Fuel: Wood or Smokeless Fuel
- Heat Output: Wood-6kw/Smokeless 7.5kw
- Efficiency: 83.9%
- Flue Size: 125mm
- Extra-large glass door
- Sleek contemporary design
- Outstanding efficiency
- Elcofire Clean Glass Technology
- Available with or without Multifuel Kit
- Cool touch handle
- External air
- Ecodesign Ready
- Easy to light and install
- Standard Top or Rear Flue outlet

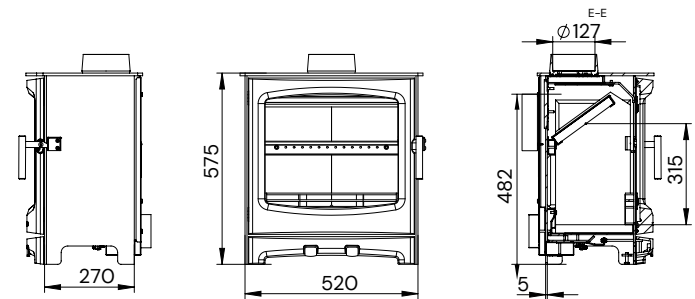

elcofire



Terra log holder

Optional
extra

Enhance your Terra Stove with the under stove log store and increase the height of stove and give you a taller look

KEY FEATURES

- Easy to install
- must be purchased and installed before installation of stove.

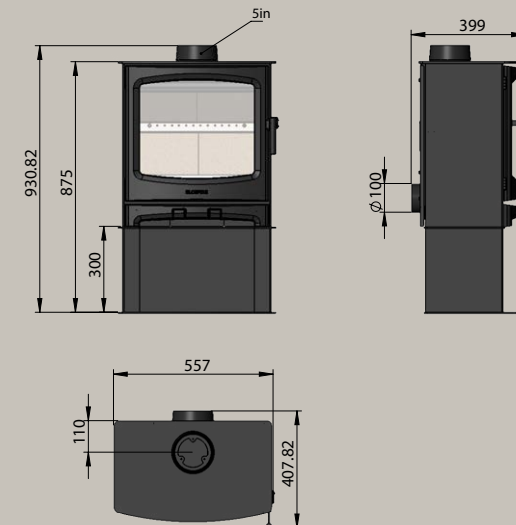



pellet stoves

The Elcofire Eco Pellet stove range is stylish, efficient, and robust. Its patented air technology with forced ventilation is whisper-quiet and suited to any room in the home, with Wi-Fi and remote control as standard for total comfort and convenience.



The Cooper Inset Pellet Stove is the first of its kind that can be retrofitted into a standard 16" fireplace with a robust design and an easy slide out drawer to load your pellets which produces an amazing 6kw of heat thanks to our new patented design.

EFCOP6s

Cooper 6s

A+

KEY FEATURES

- 3.0kw – 6.0kw Output
- Wifi & Thermostatic remote control as standard
- Additional Emergency back-up display panel
- Black ceramic bricks in heating chamber
- Cast Iron Burning Pot
- Daily & Weekly Programmer
- Silent Running Independently controllable Room fan
- Pellet consumption per hour:
Max 1.0 kg/h – Min 0.5 kg/h
- Pellet tank capacity: 11 kg
- Heated room size: 70 – 160 mc
- Easy Slide Out Loading Drawer to fill up with pellets
- Comes with Frame in 3 or 4 Sided
- Optional Base kit for 4-sided frame available
- Optional Top flue connector available for ease of installation

3 SIDED FRAME

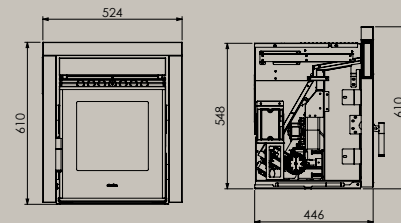

4 SIDED FRAME

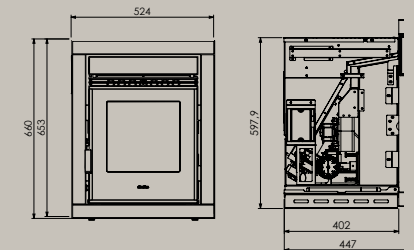

Ø80 mm

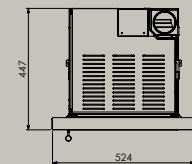
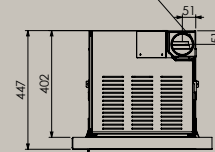



EFCOP8S

Cooper 8s

The Cooper 8 Inset Pellet Stove is a larger version of the Cooper 6s but packs a serious punch with 8kw of heat, can be retrofitted into a standard 16" or 22" fireplace with a robust design and an easy slide out drawer to load your pellets which produces an amazing 8kw of heat thanks to our new patented design.

KEY FEATURES

- 3.0kw – 8.6 kw Output
- 95,2 % Efficiency
- Wifi & Thermostatic remote control as standard
- Additional Emergency back-up display panel
- Black ceramic bricks in heating chamber
- Cast Iron Burning Pot
- Daily & Weekly Programmer
- Silent Running Independently controllable Room fan
- Pellet consumption per hour: Max 1.3 kg/h – Min 0.5 kg/h
- Pellet tank capacity: 13.5 kg
- Heated room size: 70 – 200 mc
- Easy Slide Out Loading Drawer to fill up with pellets
- Comes with Frame in 3 or 4 Sided
- Optional Top flue connector available for ease of installation

A+



elcofire

3 SIDED FRAME

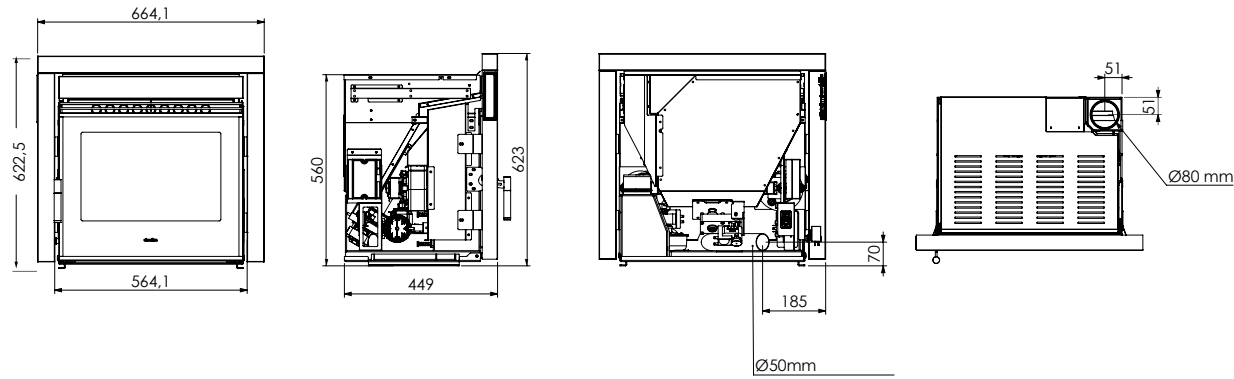

4 SIDED FRAME

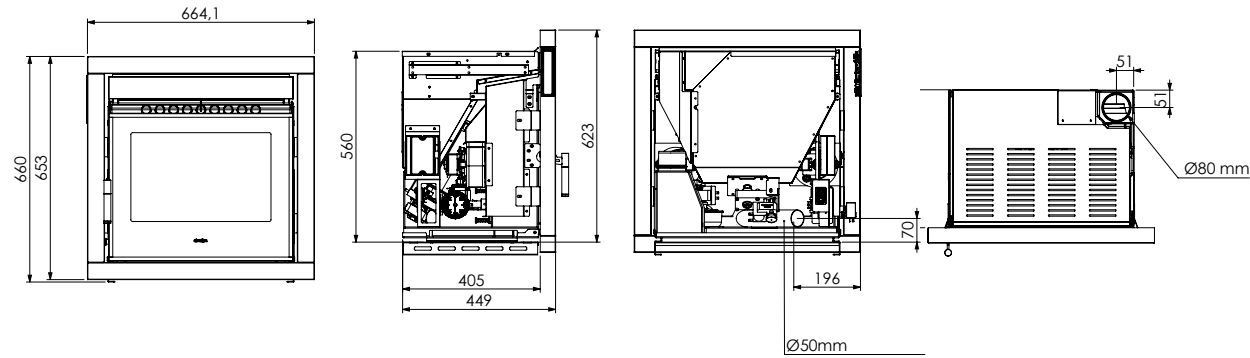

Flue options

COOPER TOP FLUE

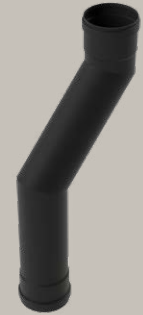

STRATA TOP FLUE



KORA TOP FLUE





EFKOP6

Kora 6s

The Kora Free Standing Pellet Stove is a small compact stove with an enhanced thermal exchanger and cast-iron door ensures maximum heat transfer while minimizing fuel consumption and be retrofitted in front of a fireplace or alcove.

KEY FEATURES

A+

- 3.0kw – 6.0kw Output
- Wifi & Thermostatic remote control as standard
- Additional Emergency back-up display panel
- Black ceramic bricks in heating chamber
- Cast Iron Burning Pot
- Cast Iron Door
- Daily & Weekly Programmer
- Independently controllable Room fan
- Pellet consumption per hour: Max 1.0 kg/h – Min 0.5 kg/h
- Pellet tank capacity: 12 kg
- Heated room size: 70 – 160 mc
- Removeable Legs to decrease height
- Optional Top flue connector available for ease of installation

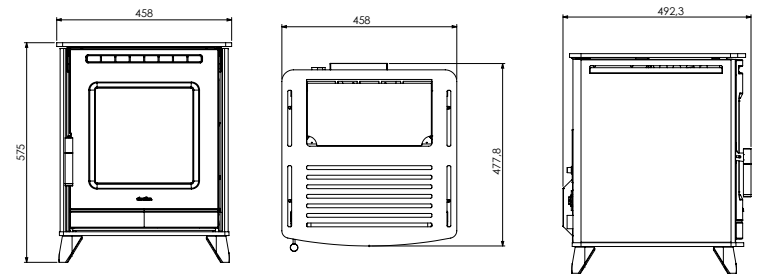

elcofire



EFKOPLS

Kora Log Store (logstore only)

Enhance your Kora Stove with the under stove log store and increase the height of stove and give you a taller look.

Optional
extra

KEY FEATURES

- Easy to install
- Must be purchased and installed before installation of stove

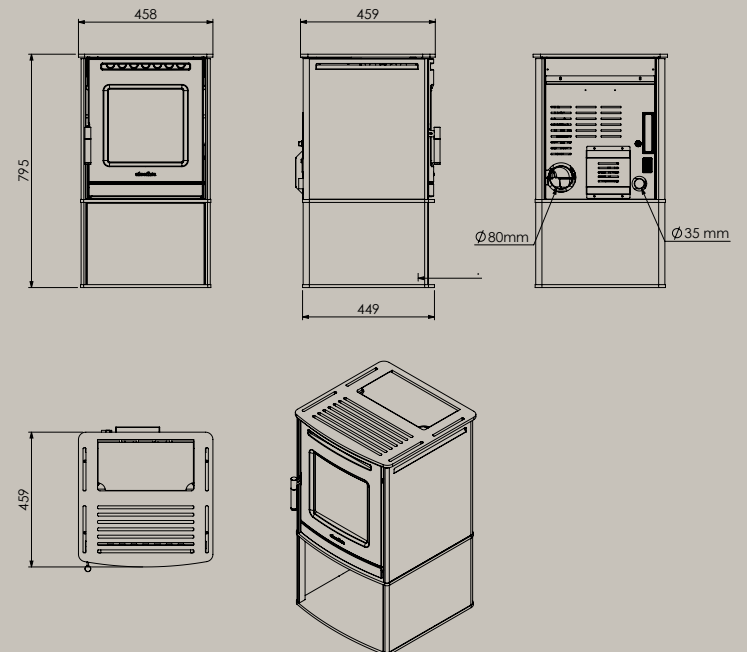



EFSTP16

Strata 17

The Strata is a small free standing pellet boiler stove with fan assisted heat to the room for central heating with an enhanced thermal exchanger and cast iron door ensuring maximum heat transfer while minimizing fuel consumption.

KEY FEATURES

- 4.5kw – 16kw Output
- Wifi Enabled as Standard
- Additional Emergency back-up display panel
- Cast Iron Burning Pot
- Cast Iron Door
- Easy access for maintenance
- Daily & Weekly Programmer
- Independently controllable Room fan
- Pellet tank capacity: 12 kg
- Heated room size: 110 – 360 mc
- Removeable Legs to decrease height
- Optional Top flue connector available for ease of installation

A+

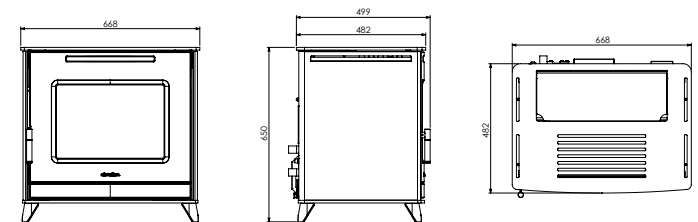

elcofire



EFSTP25

Strata 25

The Elcofire Strata 25 is the bigger sister of the famous Strata 17 Boiler which is a small free standing pellet boiler stove with fan assisted heat to the room for central heating with an enhanced thermal exchanger and cast-iron door, ensuring maximum heat transfer while minimizing fuel consumption, Strata is the most popular pellet boiler stoves in the Irish/UK Market.

KEY FEATURES

- 4.5kw – 24kw Water Output
- 94.4% Efficient
- Wi Fi Enabled as Standard
- Additional Emergency back-up display panel
- Cast Iron Burning Pot
- Cast Iron Door
- Easy access for maintenance
- Daily & Weekly Programmer
- Independently controllable Room fan
- Pellet tank capacity: 15 kg
- Heated room size: 110 – 360 mc
- Removeable Legs to decrease height
- Optional Top flue connector available for ease of installation



A+

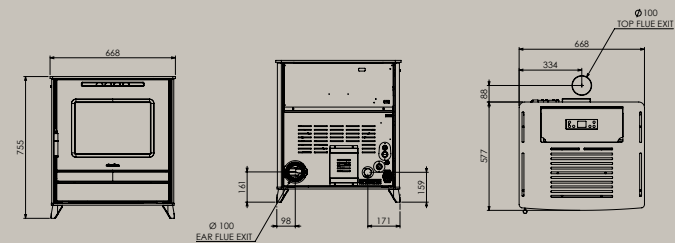



EFLIP

Lima 7 inset stove

The Lima Inset Pellet Stove is the smallest of its kind that can be retrofitted into a standard fireplace with a robust design and an easy slide out drawer to load your pellets.

KEY FEATURES

- 3.0kw – 7kw Output
- Built in 3 Button Display Touch Panel
- Wifi & Remote control as standard
- Daily & Weekly Programmer
- Cast Iron Steel Burning Pot
- Pellet consumption per hour: Max 1.0 kg/h – Min 0.5 kg/h
- Pellet tank capacity: 8 kg
- Heated room size: 70 – 170 mc
- Easy Slide Out Loading Drawer to fill up with pellets
- Available with 3 or 4 sided frames

A+

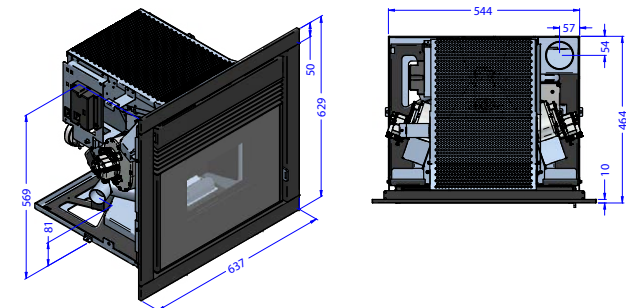

elcofire



EFLDF

Lima 7 deep fit frame

Optional extra

Introducing a deeper frame for Lima inset stove to accommodate a shallow fireplace depth.

KEY FEATURES

- Reduces the current stove depth by 55mm
- Matt Black Finish
- 3 & 4 Sided as Standard in the box

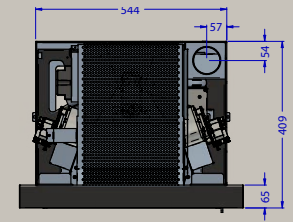
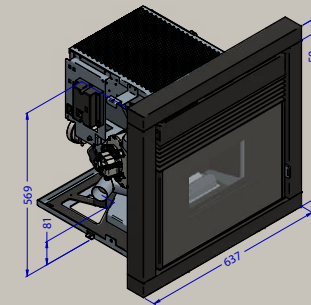



EFLIP5

Lima 5 inset stove

The Lima 5 Inset Pellet Stove is another pellet stove but with less features and more simple approach that can be retrofitted into a standard 16" fireplace with its simple design and an easy slide out drawer to load your pellets.

KEY FEATURES

- 2.5kw – 5.0kw Output
- Built in 3 Button Display Touch Panel
- Cast Iron Burning Pot
- Wifi Enabled as Standard
- Daily & Weekly Programmer
- Pellet consumption per hour: Max 1.0 kg/h – Min 0.5 kg/h
- Pellet tank capacity: 6.5 kg
- Heated room size: 70 – 150 mc
- Easy Slide Out Loading Drawer to fill up with pellets
- Optional Base kit for 4-sided frame available
- Optional Top flue connector available for ease of installation

A+

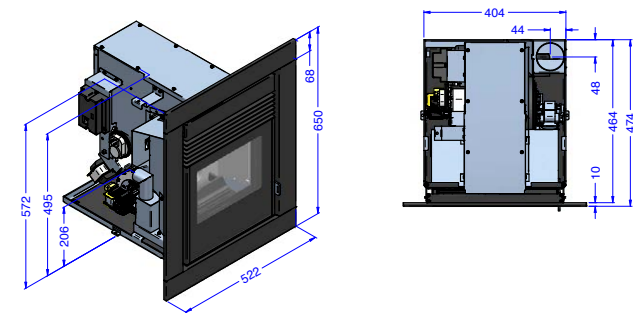

elcofire



EFLIP5

Lima 5 deep fit frame

Optional extra

Introducing a deeper frame for Lima inset stove to accommodate a shallow fireplace depth.

KEY FEATURES

- Reduces the current stove depth by 55mm
- Matt Black Finish
- 3 & 4 Sided as Standard in the box

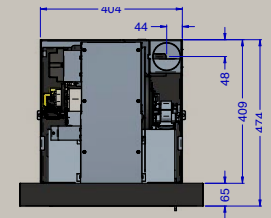
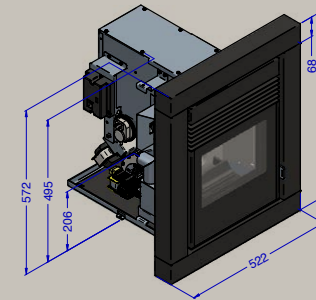
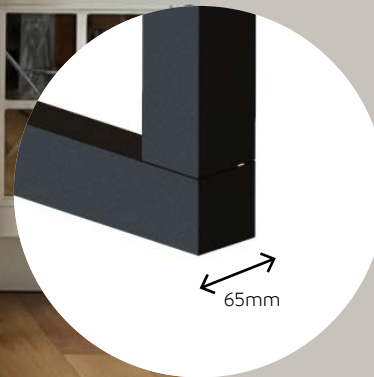



EFKIP

Kiva freestanding stove

The Elcofire Kiva is a compact pellet stove designed for efficiency and style. Its enhanced thermal exchanger delivers maximum heat transfer while reducing fuel consumption, ensuring comfort with lower running costs. The sleek new front panel, complemented by a contemporary glass door, brings a modern elegance that blends seamlessly into any room.

KEY FEATURES

- 2.5kw – 8.0kw Output
- Wi Fi enabled
- 3 Button Display Touch Panel
- Daily & Weekly Programmer
- Cast Iron Steel Burning Pot
- Pellet consumption per hour: Max 2.0 kg/h – Min 0.6 kg/h
- Pellet tank capacity: 11 kg
- Heated room size: 70 – 200 mc

A+

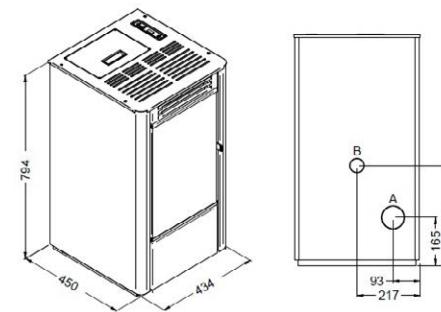

elcofire



EFKISP

Kiva slimline freestanding

The Elcofire Slimline Kiva combines all the efficiency and style of the Kiva in an ultra-slim design. Featuring the same enhanced thermal exchanger for maximum heat transfer with minimal fuel consumption, it delivers powerful performance in a space-saving format. The refined front panel and brand-new glass door create a sleek, contemporary look that brings warmth and style to any interior, even where space is at a premium.

KEY FEATURES

A+

- 2.5kw – 8.0kw Output
- Wi Fi enabled
- 3 Button Display Touch Panel
- Daily & Weekly Programmer
- Cast Iron Steel Burning Pot
- Pellet consumption per hour: Max 2.0 kg/h – Min 0.6 kg/h
- Pellet tank capacity: 11 kg
- Heated room size: 70 – 200 mc

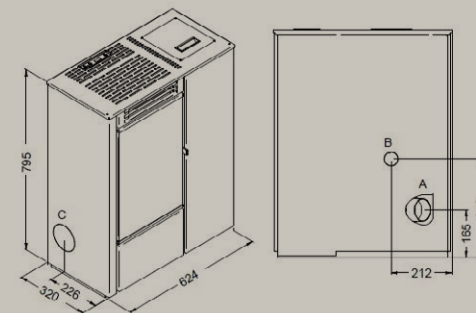



Bio Ethanol Stoves

Modern Warmth. No Chimney. No Limits. Meet Ellen – the bioethanol stove by elcofire. Where cutting-edge design meets total freedom, Ellen delivers real flame and powerful warmth at the touch of a button — no flue pipe, no gas line, no compromise. Simply plug in, pour in the bioethanol fuel, and enjoy up to 4.5kW of clean, sustainable heat. Whether it's a sleek city apartment or a quiet corner with a view, Ellen brings stunning ambiance and real fire exactly where you want it. Clean. Safe. Effortless. Beautiful.



Ellen

KEY FEATURES

- 4.5kw Output
- Simple to use display panel
- 7.8 litre Fuel Tank Storage
- High & Low Flame Height
- No Maintenance
- Silent
- Decorative Logs & Stones
- Black Curved Glass Door
- No Chimney Required
- No Smoke, no mess
- Place it anywhere you like
- Elegant & Minimalist design for any space.

A+

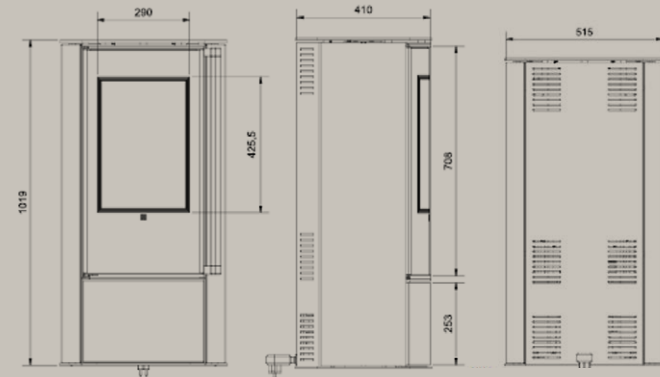

elcofire

BEYOND EXPECTATION

YOUR DEDICATED SALES AGENT:

elcofire.com    

Elcofire is part of the Nedar Heat Company